

**3 cell 12.6V 20A lithium battery protection board (with recovery function - AUTO Recovery)**
**Model: BMS-20A-3S-S & BMS-20A-3S-EFJ**

ms:72M5366,72M5373

 BMS-20A-3S-S Standard BMS 3 cell 12.6V 20A lithium battery protection board (with recovery function - AUTO Recovery)  
 Starting motor less than 60A.

BMS-20A-3S-EFJ Same as above with the difference of Starting motor less than 80A.

 Application range: Suitable for lithium batteries with a normal voltage of 3.7V and fully charged 4.2V.  
 including 1860 to 26650, Polymer lithium batteries.

PCB Size: 59 x 20x 3.4

Weight: 4.3g

Charging Voltage: 12.6 ~ 13.6V

Continuous discharge max: 20A

If heat dissipation environment is not adequate please reduce load

Continuous discharge normal: 10A

Standard version (-S): Applicable to start electric motor with current below 60A and power up to 100W.

Enhanced version (-EFJ): Applicable to start electric motor with current below 80A and power up to 100W, with interference function.

Recommended conditions:

1. 3x 10C – 20C battery cells or 6x 5C – 10C cells are required
2. Wire size should not be smaller than 2.5mm<sup>2</sup>, GND and 12.6V

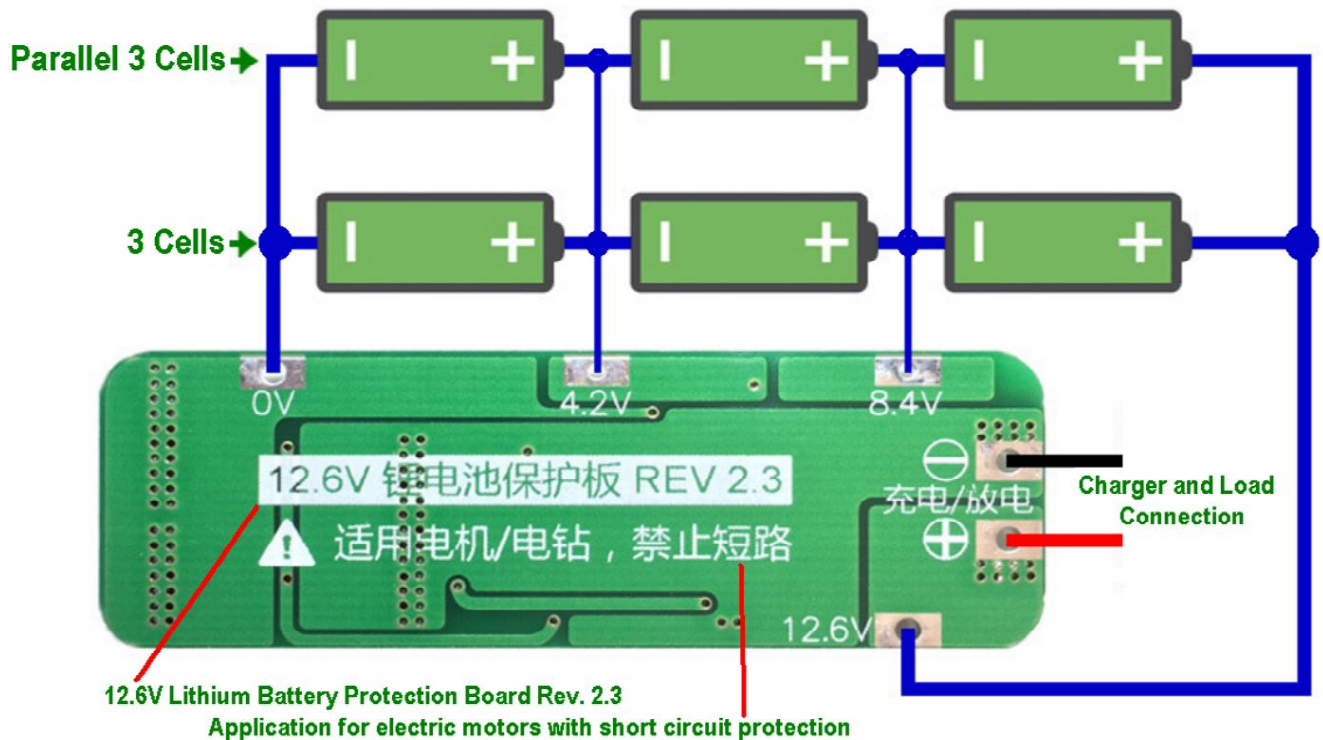

BMS-20A-3S-S

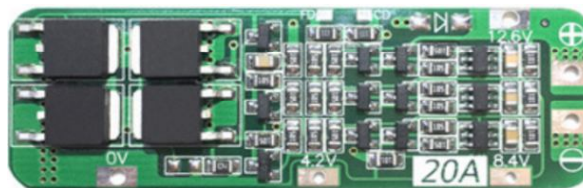

BMS-20A-3S-EFJ

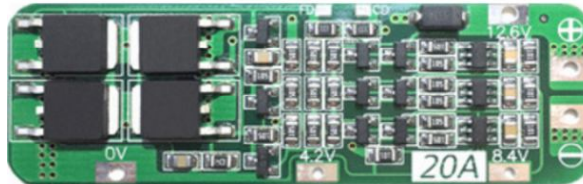



3S20A : Electric parameter	Min	Nor	Max	Unit	Notes
Self consuming current	12	18	24	uA	
Overcharge protection voltage	4.2	4.25	4.3	V	
Overcharge recovery voltage	4.1	4.12	4.2	V	
Over-discharge protection voltage A	2.4	2.5	2.6	V	
Voltage after over discharge protection	2.8	3	3.2	V	1C Discharge
Voltage after over discharge protection	3.2	3.5	3.8	V	2C Discharge
Over-discharge recovery voltage	2.9	3.2	3.3	V	
Rds (on)	10	12	14	mΩ	
Over-current protection current	56	60	64	A	
Over-current delay time	50	100	150	ms	
Continue work current	0	20	20	A	
Continue output power	0	252	252	W	
Environment temperature	-40	25	85	°C	

Trouble shooting:		
Fault phenomenon	Fault Checking and Causes	Method of fix
Unable to charge	Measure the voltage of 3 batteries. If the voltage of one group of batteries is exceeds about 4.25V, the protection board will start overcharge protection.	Match the batteries well, and don't mix the good batteries with the bad ones (normal function, no warranty)
Unable to discharge	Measure the voltage of 3 groups of batteries. If the voltage of one group of batteries is less than 2.7V, the protection board will start overcharge protection.	Match the batteries well, and don't mix the good batteries with the bad ones (normal function, no warranty)
Charge / discharge failure	0V、4.2V、8.4V、12.6V wrong connection	Rewire or renew the board (Human fault, no warranty)
Overcharge/over-discharge failure	0V、4.2V、8.4V、12.6V wrong connection	Rewire or renew the board (Human fault, no warranty)
Discharge protection	Check the battery pack whether has sufficient discharge capacity and the starting current of the load whether exceeds the over-current protection current of the protective board.	Replacement of batteries with stronger discharge or protective board with larger current (beyond working range, no warranty required)
Element virtual welding	There is no connection between one pin of the component and PCB welding.	Repair welding (Maintainable by return)
Element continuous welding	There is a short circuit between two or more pins of a component.	Remove components and re-weld (Maintainable by return)
Electrostatic breakdown A	In the absence of electricity, measure the G, D and S pins of MOS transistors. If the forward and reverse resistances of any two pins are 0Ω, it has been damaged.	Removal and replacement MOS transistors
Electrostatic breakdown B	Remove the MOS transistors and measure the resistance values of G and D poles, G and S pins. If there is breakdown, the resistance should be infinite under normal conditions.	Removal and replacement MOS transistors